

Installation Instruction

Model : 0105-0398

STEP 1. Verify all parts are present. Read instructions completely before beginning.

STEP 2. Attach the mounting brackets as shown in figure.

STEP 3. Attach step bars to mounting brackets. Inspect step bars and brackets for proper alignment. Tighten and torque M10 bolts to 20-25ft-lbs and M8 hex bolt to 18-20 ft-lbs as shown in figure.

0105-0398

DRIVER SIDE INSTALLATION SHOWN

FIGURE 1

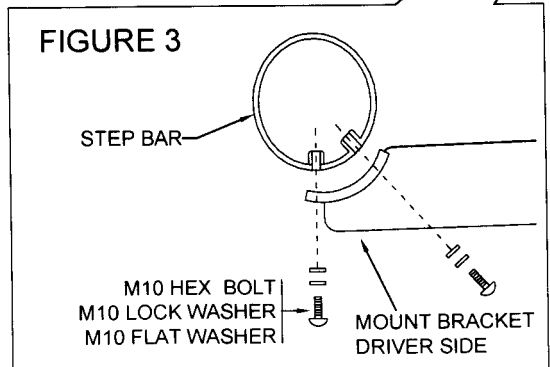
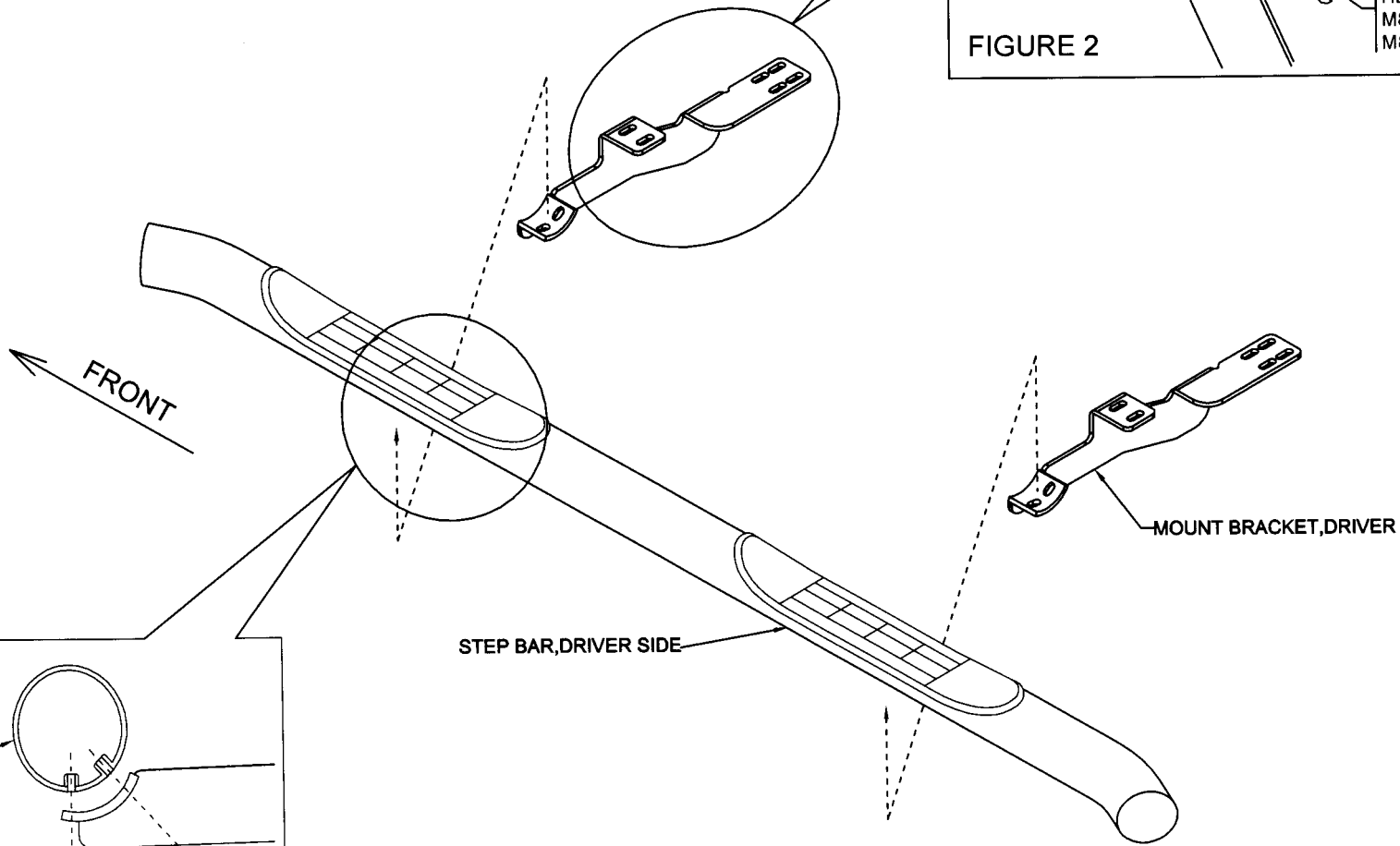
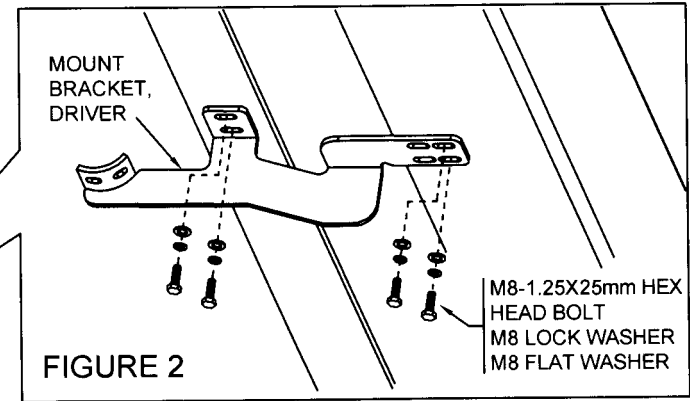

0105-0398			
Item No	Part Number	Part Description	QTY
1	0105-0398-01	STEP BAR - DRIVER SIDE	1
2	0105-0398-02	STEP BAR - PASSENGER SIDE	1
3	0105-0398-03	MOUNT BRACKET - DRIVER	2
4	0105-0398-04	MOUNT BRACKET - PASSENGER	2
5	0105-0398-11	M8 -1.25 X 25mm HEX HEAD BOLT	16
6	0105-0398-12	M8 FLAT WASHER	16
7	0105-0398-13	M8 LOCK WASHER	16
8	0105-0398-14	M10-16 X 1.25" BUTTON HEAD BOLT	8
9	0105-0398-15	M10 FLAT WASHER	8
10	0108-0398-16	M10 LOCK WASHER	8
<p>TOOLS REQUIRED 12mm/13mm SOCKET 7/32" HEXAGONAL WRHNCH RATCHET TORQUE WRENCH</p>			