

0703-0077

## 1999-11 Ford F-250 Super Duty - Crew Cab

### Components List:

- 2 – Stainless steel oval step bars
- 2 – Front Bracket – Driver & Passenger Side
- 2 – Rear Bracket – Driver & Passenger Side

### Parts List:

- 16 – M10-1.25 x 30 mm hex head bolts
- 24 – M10 flat washers
- 16 – M10 lock washers
- 8 – M10 U-Nut
- 8 – M10 Hex Nut
- 8 – M10 button head bolt
- 8 – M10 lock washers
- 8 – M10 flat washers

### Installation Instruction:

1. Remove contents from box and check for damage. Verify all the parts from the list above are present and accounted for. Please read instructions completely before starting.
2. Install extruded U-Nuts as shown for both front and rear bracket positions (**see Fig. 1 and Fig. 2**).  
**Note: For 2011 & up – only 3 bolts are required for front bracket**
3. Install passenger side front and rear bracket as shown on inside rocker panel of vehicle (**see Fig. 1 and Fig. 2**). Hand tighten.
4. Place passenger side step bar on brackets. Each step bar is marked driver and passenger.
5. Assemble with M10 button head bolts and M10 washers. 2 bolts per bracket, 4 bolts per bar (**see Fig 3**). Hand tighten.
6. Repeat installation for driver side.

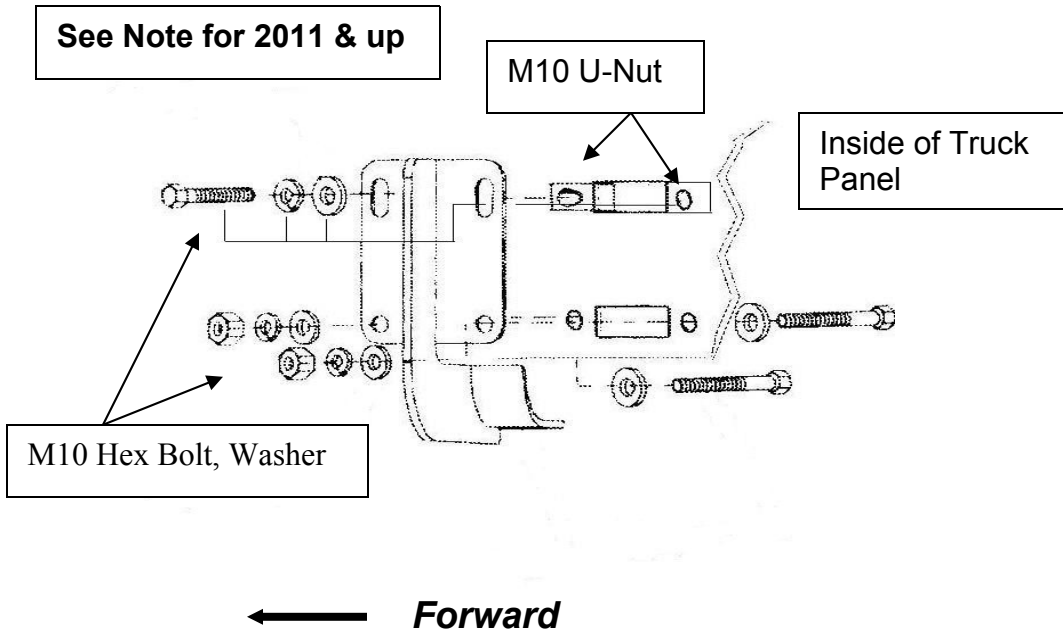

Figure 1. Passenger Side – Front

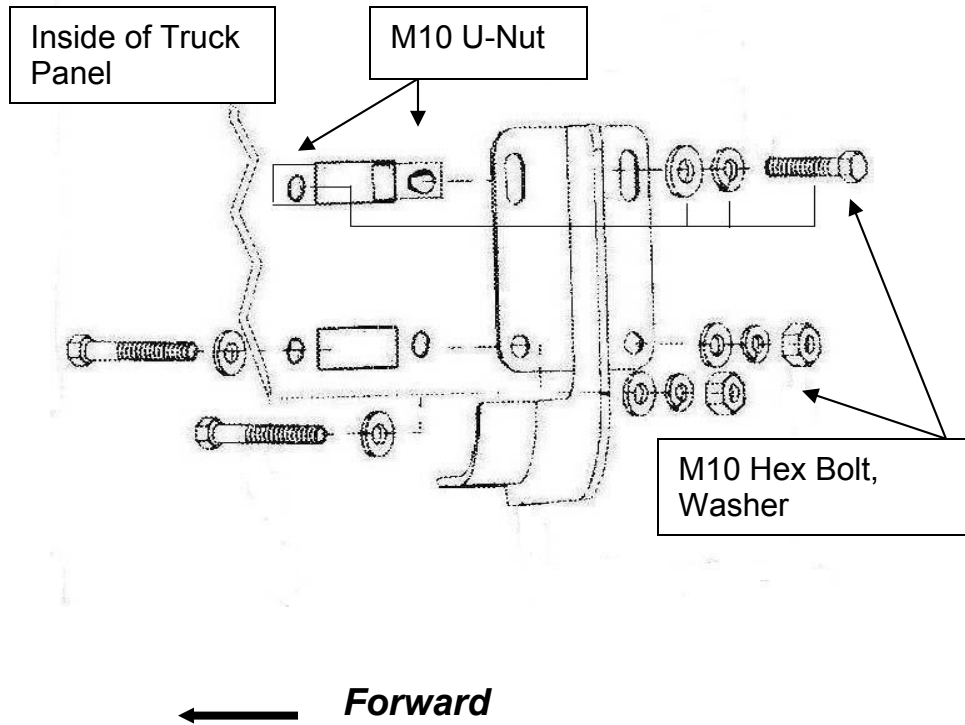

Figure 2. Passenger Side – Rear

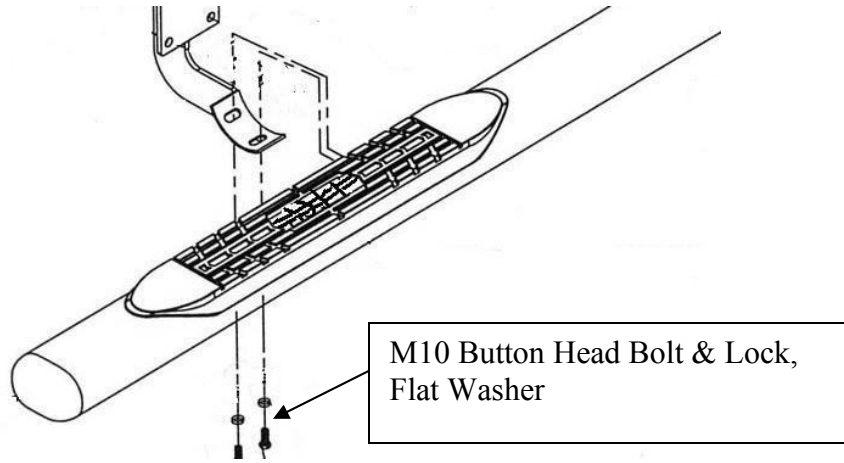

Figure 3. Installation View of Bracket & Bar